

**STRAIGHT BULKHEAD JACK,  
CRIMP AND SOLDER TYPE - CABLE 5/50 D**

**R125.278.000**

Series : SMA

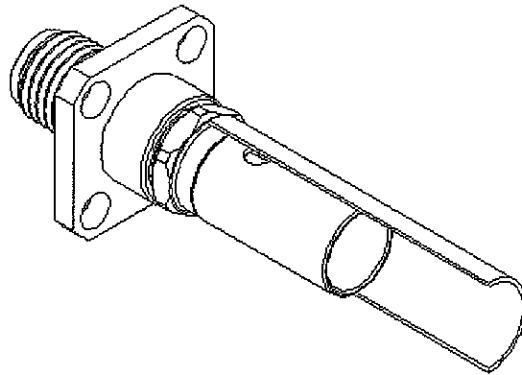
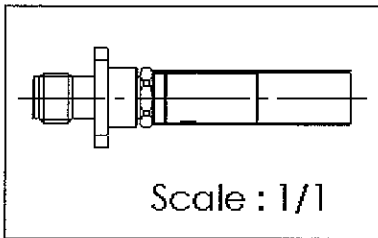
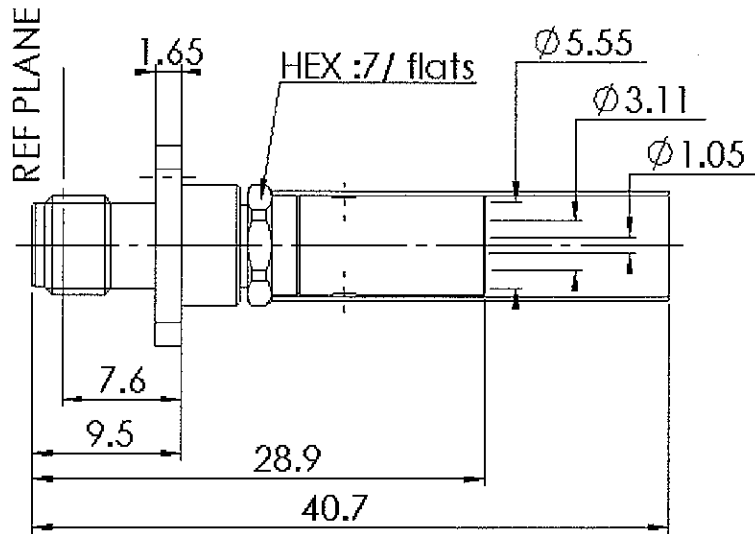
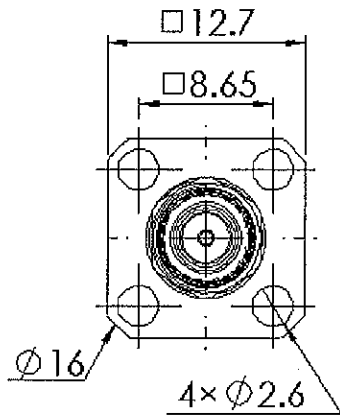

**PANEL CUT OUT**

	mm	
	Maxi	mini
A	6.6	6.5
B	2.7	2.6
C	8.69	8.59

All dimensions are in mm.

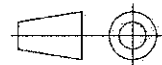

COMPONENTS	MATERIALS	PLATINGS (µm)
BODY	STAINLESS STEEL	GOLD 0.5 OVER NICKEL 2
CENTER CONTACT	BERYLLIUM COPPER	GOLD 1.3 OVER NICKEL 2
OUTER CONTACT	-	-
INSULATOR	PTFE	-
GASKET	-	-
OTHERS PARTS	BRASS	GOLD 0.2 OVER NICKEL 2
-	-	-
-	-	-

Issue : 0539 J

In the effort to improve our products, we reserve the right to make changes judged to be necessary.



**STRAIGHT BULKHEAD JACK,  
CRIMP AND SOLDER TYPE - CABLE 5/50 D**

**R125.278.000**

Series : SMA

**PACKAGING**

Standard	Unit	Other
100	'W' option	Contact us

**SPECIFICATION**

**CABLE ASSEMBLY**

Stripping	a	b	c	d	e	f
mm	2.85	7.00	18.0	0.00	8.15	0.00

**ELECTRICAL CHARACTERISTICS**

Impedance		<b>50</b> Ω
Frequency		<b>0-12.4</b> GHz
VSWR	<b>1.15</b> +	<b>0.010</b> x F(GHz) Maxi
Insertion loss		<b>0.06</b> √F(GHz) dB Maxi
RF leakage	- (	<b>60</b> - F(GHz)) dB Maxi
Voltage rating		<b>335</b> Veff Maxi
Dielectric withstanding voltage		<b>1000</b> Veff mini
Insulation resistance		<b>5000</b> MΩ mini

Assembly instruction :

Recommended cable(s)  
KX 23  
RG 142 FTX  
RG 142  
RG 400  
RG 223

**MECHANICAL CHARACTERISTICS**

Center contact retention		
Axial force – Mating end	<b>27</b>	N mini
Axial force – Opposite end	<b>NA</b>	N mini
Torque	<b>NA</b>	N.cm mini
Recommended torque		
Mating	<b>NA</b>	N.cm
Panel nut	<b>NA</b>	N.cm
Clamp nut	<b>100</b>	N.cm
A/F clamp nut	<b>7.000</b>	mm
Mating life	<b>500</b>	Cycles mini
Weight	<b>5.800</b>	g

Cable retention

- pull off	<b>204</b>	N mini
- torque	<b>NA</b>	N.cm

**TOOLING**

Part Number	Description	Hexagon
R282.223.000	CRIMPING TOOL	5.40
R282.293.000	CRIMPING TOOL	-
R282.235.011	CRIMPING DIES	5.40

**OTHERS CHARACTERISTICS**

**ENVIRONMENTAL**

Operating temperature	<b>-65/+165</b>	° C
Hermetic seal	<b>NA</b>	Atm.cm3/s
Panel leakage	<b>NA</b>	

Issue : 0539 J

In the effort to improve our products, we reserve the right to make changes judged to be necessary.



**RADIALL**®

**STRAIGHT BULKHEAD JACK,  
CRIMP AND SOLDER TYPE - CABLE 5/50 D**

**R125.278.000**

Series : SMA

COMPONENTS

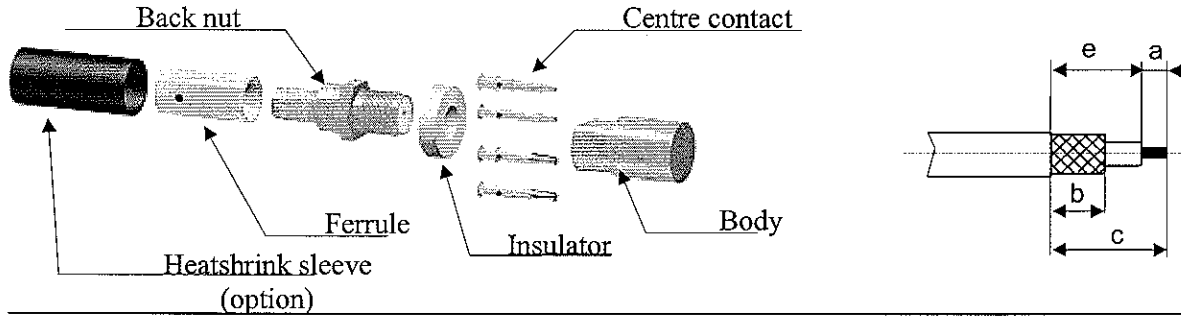

**1**

Slide the heatshrink sleeve onto the cable (Option).  
Slide the ferrule onto the cable.  
Position the ferrule's hole at the front if soldering.  
Position the ferrule's hole at the back if crimping.  
Strip the cable.

**4**

Slide the centre contact on until it bottoms against the insulator back nut.  
Solder or crimp the contact ( see connector TDS ).

**2**

Fan the braid.  
Slide the cable into the back nut.

**5**

Screw the back nut into the connector body with the adapted wrench.  
Recommended coupling torque ( see connector TDS)

**3**

Slide the ferrule over the braid.  
Crimp the ferrule with crimping tool ( see connector TDS ).

**6**

Slide the sleeve over the ferrule and heatshrink it in place (option).

Issue : 0539 J

In the effort to improve our products, we reserve the right to make changes judged to be necessary.

